

Installation Instructions

3M Model 491AA D-120 12-Channel Intracom 78-9236-5183-6

Table of Contents

Installation Subjects	Page
Introduction	2
Special Notes and Requirements	3
Installation Preview	4
Intracom Mainstation Installation	6
Installing Remote Components	7
Installation Options	7
Configuration (Setting Switches and Jumpers)	10
Keypad Channel Identification	10
Volume Adjustments and Function Checks	10
Music Player Installation	13
Speaker/Mics, Call Switches and Accessories	14
Service Information	15

Illustrations	Page
Outside Connections	4
Inside Connections	4
Table Mount, Minimum Extension	5
Table Mount, Maximum Extension	5
Wall Mount, Standard	5
Wall Mount, Side Angle	5
Pedestal/Mounting Bracket Assembly	5
Mounting Bracket Features	5
Attaching the Mounting Guides	6
Wall Mounting	6
Channel 1-6 Connections	8
Channel 7-12 Connections	9
Configuration Switches	10
Power Transformer Connections	11
TALK and ALERT Volume Adjustments	11
Music Player Connections	13

To the installer:
Be sure to review the "Before you proceed" instructions on page 3.

INTRODUCTION

The Model 491AA D-120 Intracom provides communication links with up to 12 remote locations. Using a speaker/mic, OSM or handset at each location, communications can occur between the intracom mainstation and each separate location or with all locations at once.

With its 12-channel capability, the D-120 is well suited for use in gasoline stations, truck stops and convenience stores for communications between the store and gasoline pump islands. With all connections made via four plug-in cables at the rear of the D-120, up to 12 speaker/mics can be accommodated along with 12 call switches to provide alert tones for each channel.

While all D-120 functions can be controlled and monitored from its control panel, its ease of use can be further enhanced by connecting an inside flex mic, footswitch and monitor speaker.

The D-120's membrane switch panels provide TALK, LISTEN, HOLD, ALL CALL, and STANDBY functions. Viewing the D-120 front panel, the switch panel on the left controls communications with channels 1 - 6; the switch panel on the right controls channels 7 - 12.

TALK/LISTEN

Press the desired numbered channel selector switch. A red indicator above the switch lights to indicate the TALK mode. The talk mode remains in operation as long as the switch is pressed. Releasing the channel selector switch places that channel in the LISTEN mode. A green indicator above the switch turns on to indicate this mode. If an optional "switched" microphone or footswitch is used, talk/listen switching is controlled by the microphone switch or footswitch (after first pressing the channel selection switch).

ALL CALL

Pressing either of the ALL CALL switches allows you to talk or listen to all channels at the same time. Talk/listen switching occurs as described for TALK/LISTEN above with the red and green indicators lighting for all channels.

HOLD

The HOLD switch on the left controls channels 1 - 6. The HOLD switch on the right controls channels 7 - 12. Momentarily pressing either HOLD switch places a selected channel on hold, "muting" channel communications. The yellow indicator light indicates the channel on hold. Re-establish communication by depressing the selector switch for the channel on hold.

STANDBY

Touch either STANDBY switch to silence the selected channel when the unit is not in use. An indicator above the switch lights to signal that the STANDBY mode is in use.

CALL ALERT

Call switches at the remote locations cause the yellow indicator to flash above the calling channel and sound an audible tone to announce the incoming call. (The D-120 can be configured for either a single or repeating pulse alert tone.) Touch the calling channel's selector switch to cancel the alert tone and establish the talk mode. Note that because channels 1-6 and channels 7-12 have separate tone circuits, it is possible that two tone signals will be heard simultaneously.

SPECIAL NOTES AND REQUIREMENTS

1. Check that all ordered equipment has been included in your shipment.

3M Part Number	Description	Quantity
78-9236-5183-6	D-120 12-Channel Intracom Mainstation	1
78-8028-8990-3	Mounting Bracket	1
78-8028-9029-9	Mounting Guide	4
26-1000-4190-9	Screw, 6-20 x 1/4-inch	4
26-1004-2046-7	Screw, 6-32 x 3/16-inch	8
78-8050-8524-4	Cable Assembly, 8-foot, 9-pair	4
78-8028-9182-6	Label, Cable "A"	1
78-8028-9181-8	Label, Cable "B"	1
78-8069-2551-3	Label, Cable "C"	1
78-8069-2552-1	Label, Cable "D"	1
78-8050-8525-1	Decal, "A" and "B" Terminal Strips	1
78-8069-2554-7	Decal, "C" and "D" Terminal Strips	1
26-1004-3480-7	Terminal Strip, 9-terminal	8
78-6911-2383-6	Transformer, Plug-in	1
78-8028-9075-2	Screwdriver/Switch Tool	1
44-0005-0302-7	Operating Instructions	1
78-8028-9194-1	Warranty Card	1
34-7016-3597-0	Dealer Receiving Card	1
78-8069-2539-8	Installation Instructions	1

2. Before you proceed:

- Be sure that all speakers to be used are of the 8-ohm variety. Use of speakers with different impedances will affect audio quality. To provide equal volume levels for each speaker, all speakers should be of the same type.
- Be sure that all call switches are of the normally open, momentary contact type. All outdoor speaker/mics etc. must be weather-resistant, approved for outdoor use. (All 3M-provided intracom outdoor components meet these requirements. See page 14.)
- All remote wiring must be twisted-pair 18-gauge or 20-gauge, individually shielded pairs, with shields connected to ground **inside the store**. (i.e. Belden #9402, two twisted pair, 20-gauge, individually shielded. Or, Belden #8762, single, shielded, twisted pair, 20-gauge.)
- All speaker and switch cables to the outside must be routed through conduit that is **SEPARATE** from conduit containing 120 VAC power wiring and **SEPARATE** from any pump/dispenser electronics.



WARNING:
DO NOT, UNDER ANY CIRCUMSTANCES, ROUTE AUDIO OR LOW VOLTAGE CABLES IN THE SAME CONDUIT WITH 120 VAC WIRING. THIS VIOLATES NATIONAL ELECTRICAL CODE AND PRESENTS A SAFETY HAZARD.

INSTALLATION PROCEDURE

Installation of the D-120 consists of four basic procedures:

1. Installing the D-120 Intracom (and its A - D terminal strips for connection to the remote locations)
2. Installing the speaker/mics, handsets etc. at the remote locations, connecting them to the D-120 terminal strips
3. Configuring the D-120 for alert tone type, microphone type etc.
4. Volume adjustments and function checks

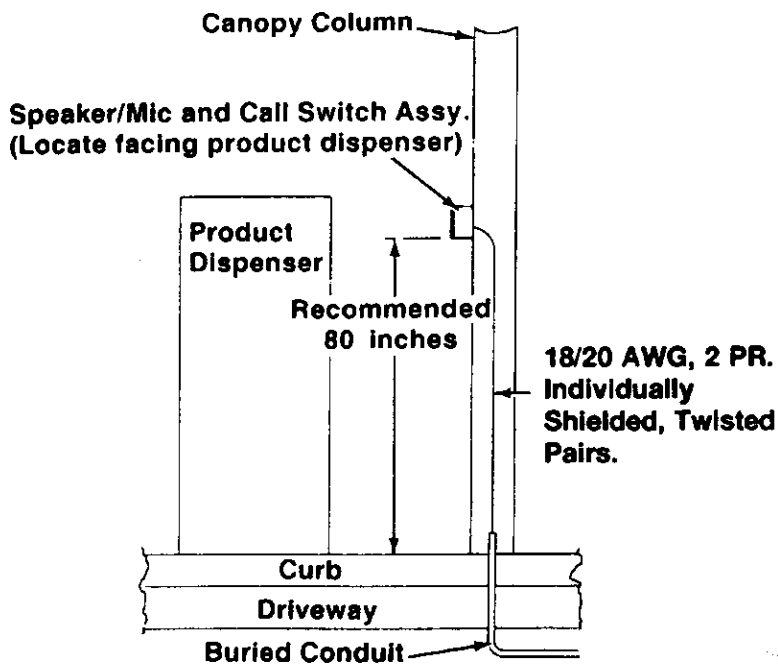

Figure 1 - Outside Connections

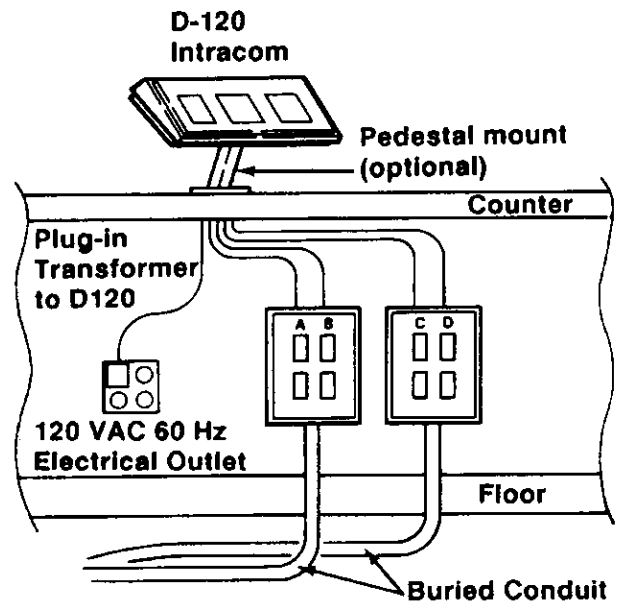

Figure 2 - Inside Connections

SPECIAL NOTE:

Figures 3 through 9 on the following pages show different pedestal mount configurations and mounting bracket details. Your installation may or may not require a pedestal mount.

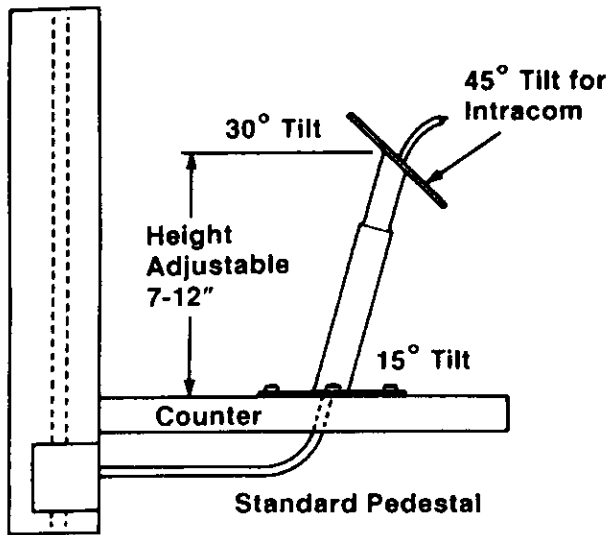

Figure 3 - Table Mount, Minimum Extension

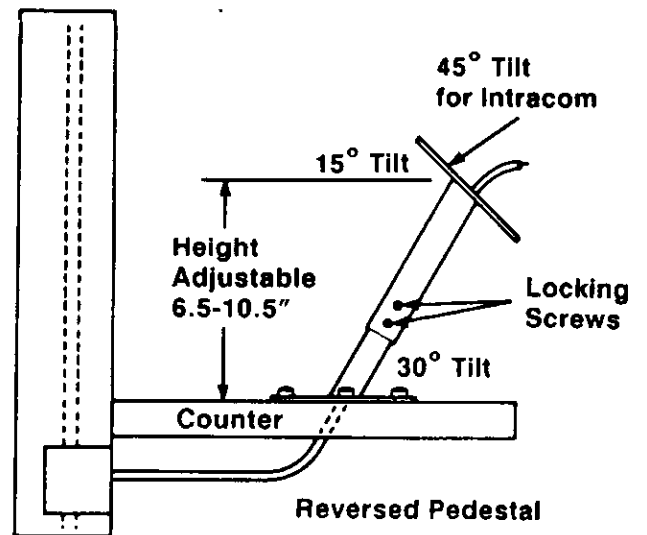

Figure 4 - Table Mount, Maximum Extension

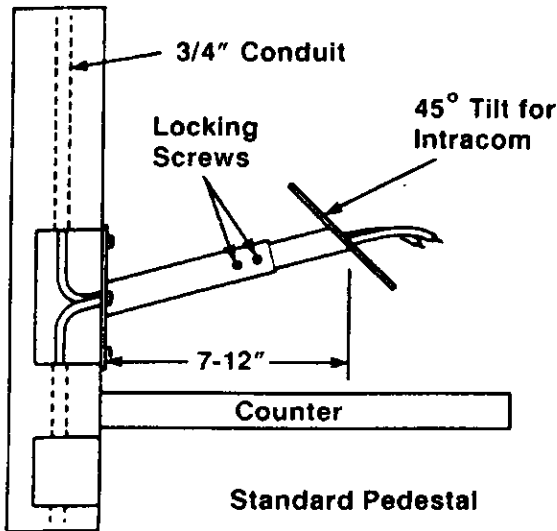

Figure 5 - Wall Mount, Standard

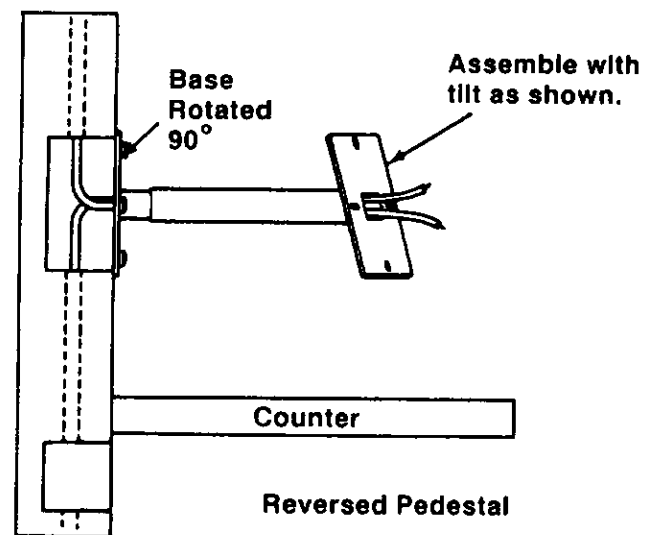

Figure 6 - Wall Mount, Side Angle

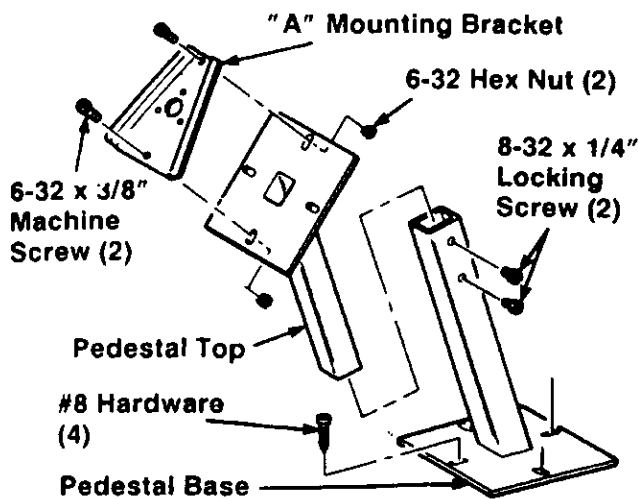

Figure 7 - Pedestal/Mounting Bracket Ass'y

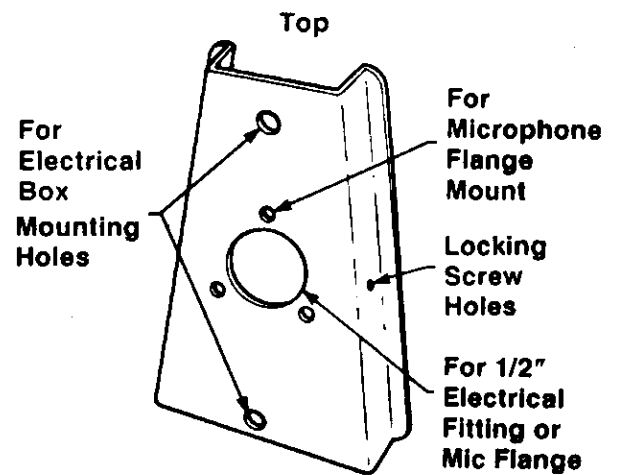

Figure 8 - Mounting Bracket Features

INTRACOM MAINSTATION INSTALLATION

Note: Instructions 3-8 apply only to pedestal mount or wall mount installations.

1. Determine where the D-120 intracom is to be positioned; near the data console and/or the cash register etc.
2. If the D-120 is to be mounted on a counter, at the selected position, drill a 1-1/2 inch hole in the counter top. This hole is for the intracom cables.
3. If the D-120 is to be pedestal-mounted, refer to figures 3 - 7 and install the pedestal mount as required.

For counter-top mounting, fasten the mounting bracket over the hole drilled in step 2.

4. As shown in figure 9, attach mounting guides to the bottom of the intracom.
5. As shown in figure 7 on the preceding page, attach the "A" mounting bracket to the pedestal mount (or to the electrical box as shown in figure 10 - if mounting to the wall).
6. At the rear of the intracom, plug in the A, B, C, and D cables. If the cables are not labeled as A - D at each end, do so now, using the labels provided.
7. Feed the cables through the A-shaped mounting bracket (and pedestal or electrical box) to the terminal strips. *Using a commercially available electrical cable lubricant or its equivalent will make this task easier.*

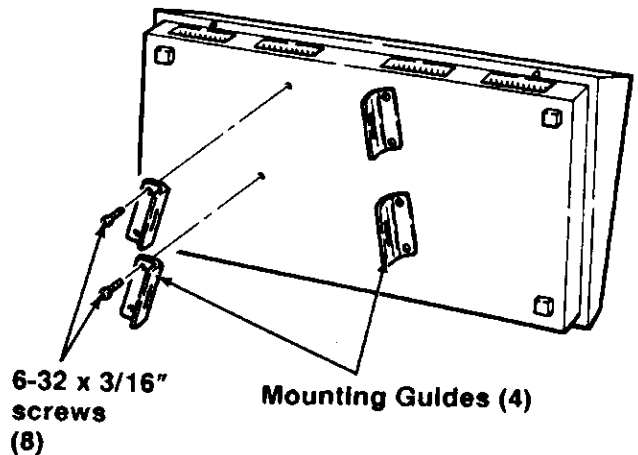

Figure 9 - Attaching the Mounting Guides

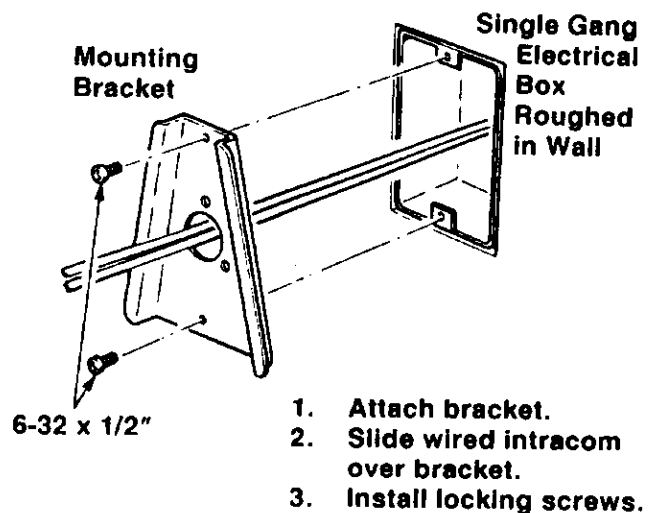

Figure 10 - Wall Mounting

8. Temporarily attach the intracom to the A-shaped mounting bracket. Use the four 6-20 x 1/4" screws to do this.
9. Fasten the decals and terminal strips to a 12" by 24" board or panel enclosure. First fasten the decals, then fasten the terminal strips over the decals - in the marked positions.
10. With reference to the wiring diagrams on pages 8 and 9:
 - a. Separate and connect the wires of the B cable to the B connector terminal strips for channels 1 - 4. Match the incoming speaker/mic and switch wires to the corresponding channels, speaker #1 to channel #1 etc.
 - b. Separate and connect the wires of the A cable to the related A connector terminal strips for channels 5 and 6.
 - c. Separate and connect the wires of the D and C cables to their related terminal strips. Cable D is for channels 7 - 10. Cable C is for channels 11 and 12.

INSTALLING REMOTE COMPONENTS

1. Install speaker/mics, call switches etc. in accordance with the 3M application guide and included instructions.
2. With reference to wiring diagram figures 11 and 12 on the following pages, connect the remote components to their related A - D terminal strips as shown. Note that the wiring diagrams show connections for several different types of remote speakers, call switches, etc. Your application will probably not be as varied.

INSTALLATION OPTIONS

Heavy-duty Security Handset

A heavy-duty, security handset (3M part number 78-6911-2379-4) may be installed outside, on a canopy post, in place of the security mic/call switch assembly. Refer to the heavy-duty security handset installation instructions for connection and configuration information. Wiring connections are shown on figure 11, page 8.

Flex Microphone

You can connect an external microphone to the D-120 in place of its internal electret microphone. For best results, use one of the following 3M microphones:

- Flex mic without switch (3M part number 78-8010-4847-7) - This microphone provides talk activation by pressing any of the numbered channel selection keypads or stepping on a separate footswitch.
- N.O. (normally-open) flex mic (3M part number 78-8010-4873-3) - This microphone provides a grip-to-talk function in addition to normal talk activation via the numbered channel selection keypads or a separate footswitch.

Note that if the switched microphone is used, its switch wiring must be connected to terminals 9 and 10 of terminal strip A and also to terminals 9 and 10 of terminal strip C. See figures 11 and 12 (wiring diagrams) for connections.

Premium Heavy Duty Footswitch

A premium heavy duty footswitch (3M part number 78-6911-1442-1) can be installed to eliminate the need to hold the channel selection switch depressed to initiate or sustain the TALK mode. Note that if the footswitch is used, its wiring must be connected to terminals 9 and 10 of terminal strip A and also to terminals 9 and 10 of terminal strip C. See figures 11 and 12 (wiring diagrams) for connections.

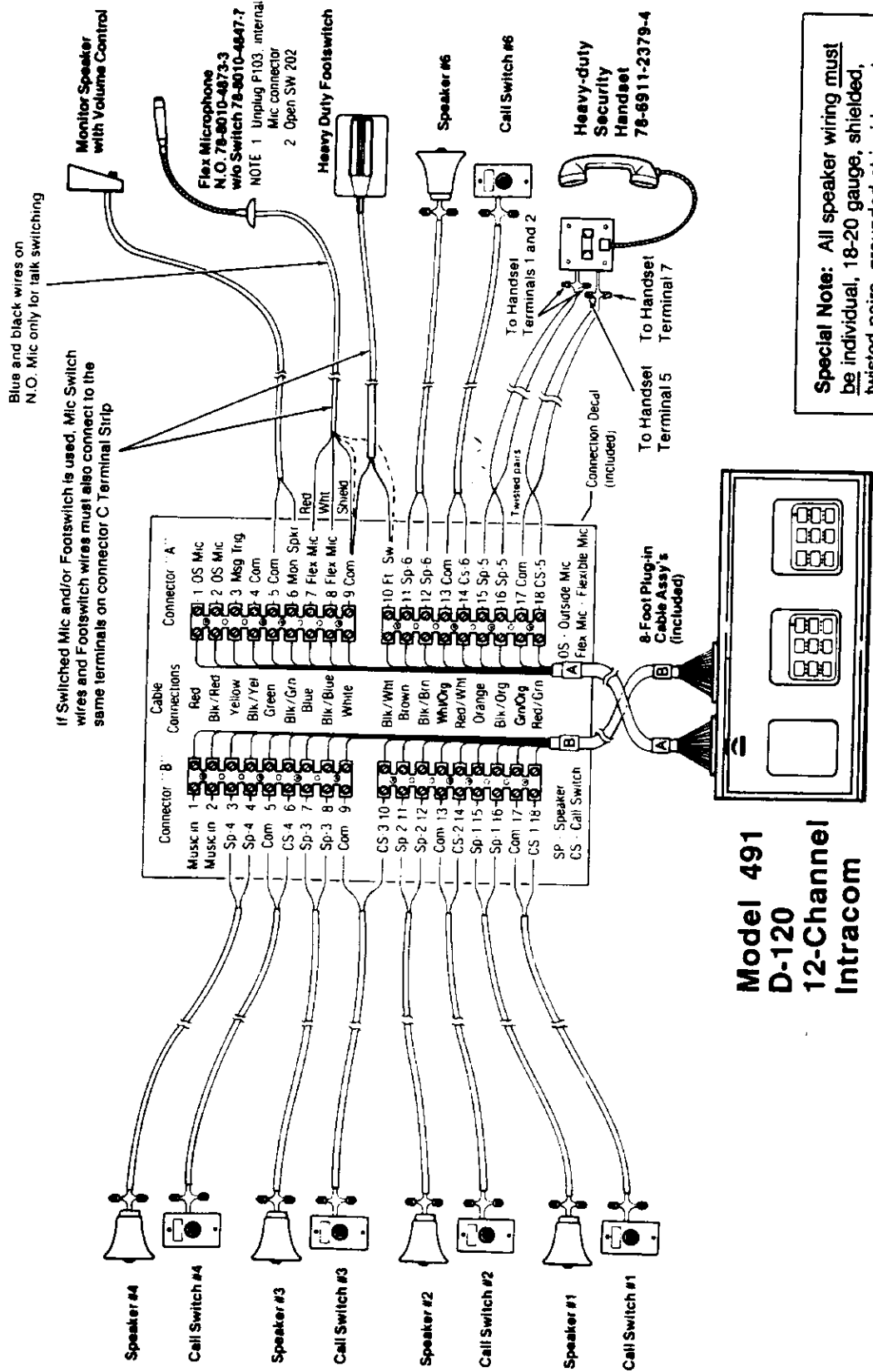
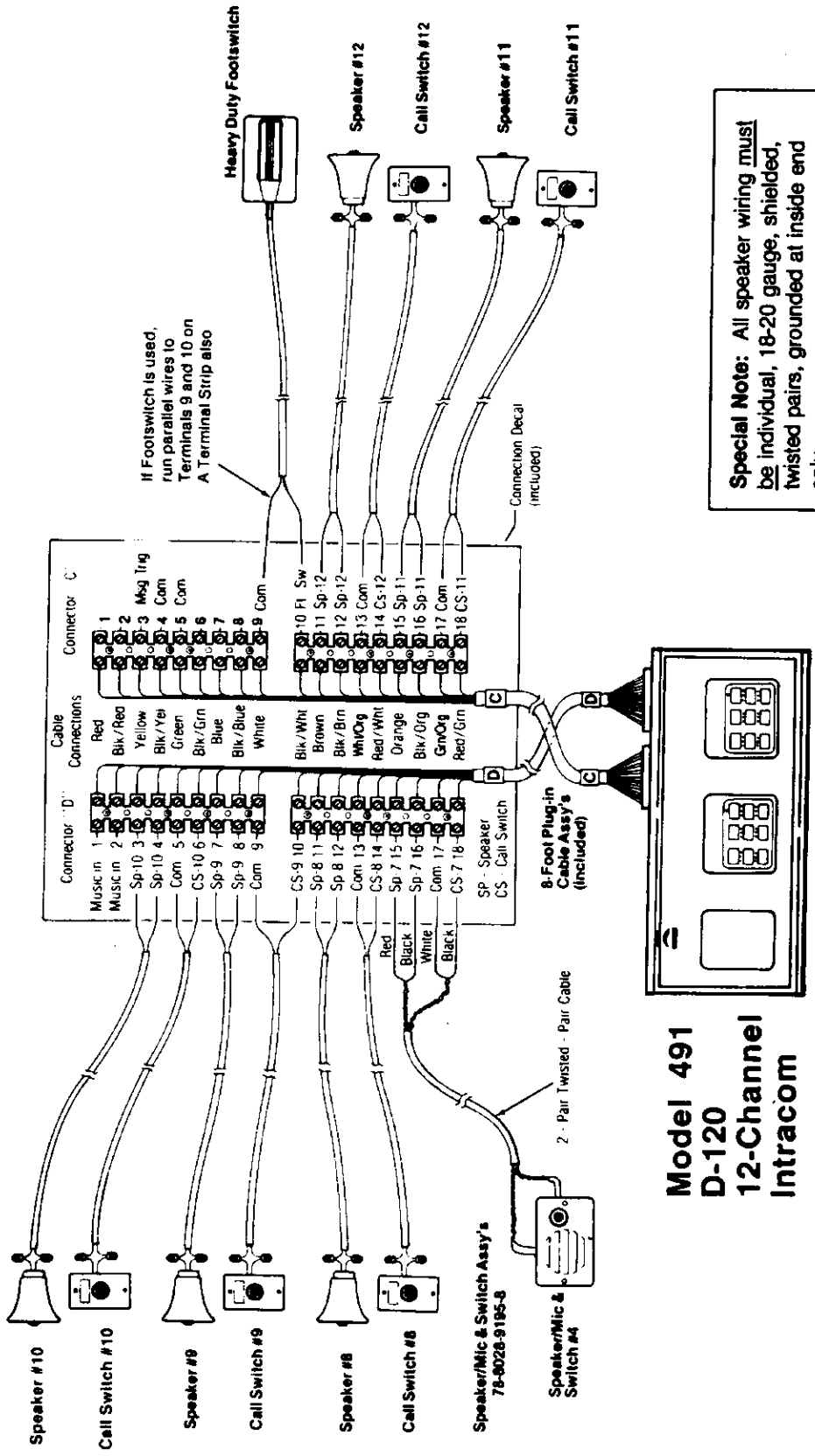

Figure 11 - Channels 1 - 6, A and B Terminal Strip Connections



Special Note: All speaker wiring must be individual, 18-20 gauge, shielded, twisted pairs, grounded at inside end only.

**Model 491
D-120
12-Channel
Intracom**

Figure 12 - Channels 7 - 12, C and D Terminal Strip Connections

CONFIGURING THE D-120 (Setting Option Switches and Jumpers)

Certain D-120 configurations may require you to change internal switches and jumpers. To do this:

1. Turn the D-120 over and remove the four flange-fastening screws.
2. Carefully separate the upper and lower cabinet panels.
3. At the lower panel PC-board locations shown in figure 13, open or close the related switch(es) to configure the D-120. Note that to modify the alert tone for all channels, you must change the condition of SW203 on both PC-boards.

D-120 Bottom Chassis Interior

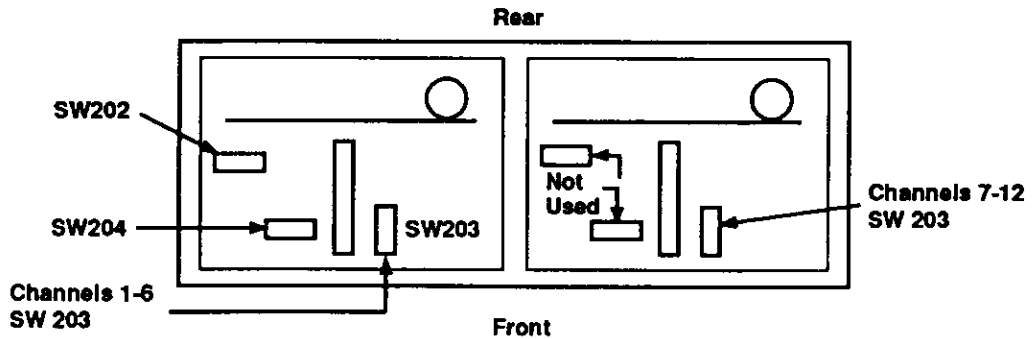

Figure 13 - Configuration Switches

Single or repeat alert tone in standby (always single tones in listen)

- Slowly repeated call alert tone in standby
- Single call alert tone in standby

* SW203 OPEN
SW203 CLOSED

Type of TALK microphone used (talk preamp gain select)

- Using built-in electret microphone or outside handset (low gain)
- Using external flex mic (high gain) *UNPLUG INTERCOM MIC*

* SW202 CLOSED
SW202 OPEN

Using low gain or high gain "listen" inputs

- Listen input is a speaker or handset (low gain)
- Listen input is a mic (high gain)

* SW204 CLOSED
SW204 OPEN

* Factory setting for this option

4. Carefully rejoin the cabinet panels, making sure that cables are not pinched between the panels.
5. Reinstall the four screws.

KEYPAD CHANNEL IDENTIFICATION

To ease the D-120 operator's task, it helps to identify which speaker is activated when a number keypad is pressed. For example, keypad #1 = island 1, pumps 1 - 4. You can do this by attaching small labels adjacent to the number keypads or by making a list of keypad-speaker combinations. Attach the list on or near the D-120.

VOLUME ADJUSTMENTS AND FUNCTION CHECKS

The D-120 has an external "listen" volume control for the operator and three internal volume controls; TALK - for all channels, ALERT - for channels 1 - 6, and ALERT for channels 7 - 12. The internal volume controls require adjustment through the bottom of the D-120 before you fasten the D-120 on its pedestal. Note that the internal TALK volume controls the volume of the outside speakers on all channels.



WARNING:
WHEN YOU MAKE THE INTERNAL VOLUME ADJUSTMENTS, USE EXTRA CARE AND THE SPECIAL SCREWDRIVER ENCLOSED WITH THE D-120. EXCESSIVE FORCE WILL BREAK THE VOLUME CONTROLS.

Power On

1. Connect the D-120 input power wires to the plug-in transformer as shown in figure 14.
2. Plug the power transformer into the 120 VAC, 60 Hz outlet.

Note that random combinations of the indicators for the channel keypads will light upon power-up. Rub a finger across each row of numbered channel keypads to clear these lights before use.

3. Set the listen volume (operator's knob at top left) to its mid-position.

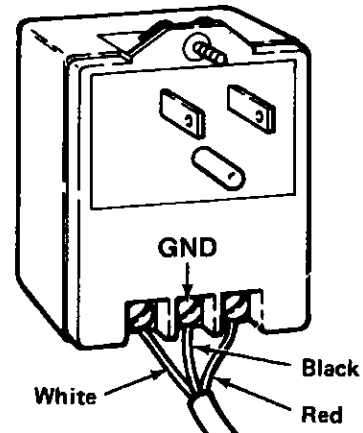

Figure 14 - Transformer Connections

TALK Volume Control

4. Press and hold any one of the channel selection keypads. The red indicator above the keypad will light to indicate the TALK function is selected. Using the small plastic screwdriver (special tool), adjust the internal TALK VOLUME control for the desired talk volume level to be heard over all outside speakers. See figure 15.
5. Release the keypad. The green indicator above the keypad will light, indicating that the listen function is selected.
6. Press the STANDBY keypad. This cancels the listen function and the yellow indicator above the STANDBY keypad will light.

View of D-120 Bottom

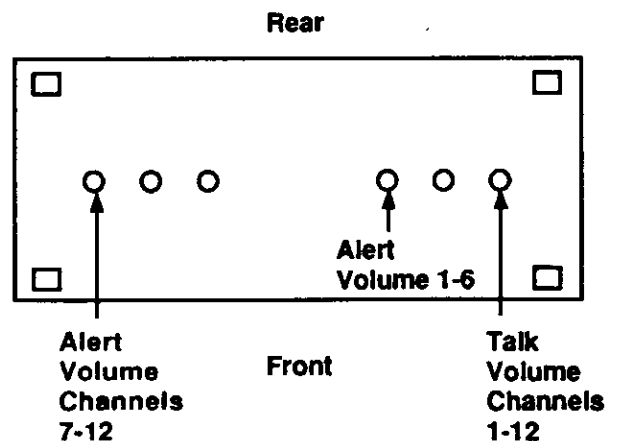

Figure 15 - TALK and ALERT Adjustments

VOLUME ADJUSTMENTS AND FUNCTION CHECKS (cont'd)**Test ALERT - ALERT Volume Control**

7. Activate any one of the channel 1 - 6 outside call switches. Switch closure should cause the yellow indicator above the corresponding keypad to flash and a single or slowly repeating alert tone will be heard from the intracom speaker. If necessary, adjust the channel 1 - 6 ALERT VOLUME, using the small plastic screwdriver (special tool.) See figure 15.
8. Activate any one of the channel 7 - 12 outside call switches. Switch closure should cause the yellow indicator above the corresponding keypad to flash and a single or slowly repeating alert tone will be heard from the intracom speaker. If necessary, adjust the channel 7 - 12 ALERT VOLUME, using the small plastic screwdriver (special tool.) See figure 15.
9. Check each of the remaining channels for talk volume, alert activation and alert volume.

HOLD Function Test

10. Press and release any channel keypad. Then press and release the corresponding HOLD keypad. The yellow indicator above the selected channel keypad will light and remain lit.

To clear a channel that is on HOLD, press and release the channel (number) keypad. The channel then returns to the listen mode.

Test ALL CALL and STANDBY Functions

11. Press and hold either ALL CALL keypad. The red indicators above each channel keypad will light and remain lit, indicating all channels are in the talk mode.
12. Release the ALL CALL keypad. The green indicators above each channel keypad will light and remain lit, indicating that all channels are in the listen mode.
13. Press either STANDBY keypad to clear the ALL CALL function.
14. If this installation includes a footswitch, flex mic, or handset, check their operation and talk/listen-switching function.
15. Instruct the store personnel in the operation of the system and leave the Intracom Operating Guide for their reference. Be sure to leave information that identifies which numbered keypads (channels) relate to which outside speakers.
16. Keep these instructions for reference.

MUSIC PLAYER INSTALLATION

To provide music over all of the speakers connected to the D-120, connect the 8-ohm output of an amplifier of 15 watts or more power to terminals 1 and 2 of both the B and D terminal strips. See figure 16. (Calling any channel on the D-120 will mute the music or messages for the called channel only.)

Be sure to run a jumper wire from the COMMON of the intracom to the chassis (or common) of the amplifier that is connected to the music/message input of the D-120. Failure to do this can cause the D-120 to play the music/messages through the D-120 front panel speaker.

Special Note: Music or messaging "crosstalk" (music or messages are heard in the base station speaker) can occur if: separate, twisted pair wiring is not used for OSM connections or, if an extremely high level of music/message is used. If crosstalk occurs, cut the red and red/blk pairs about two inches from both the B and D connectors and then connect the music/message source directly to the D-120, bypassing the 8-foot cables.

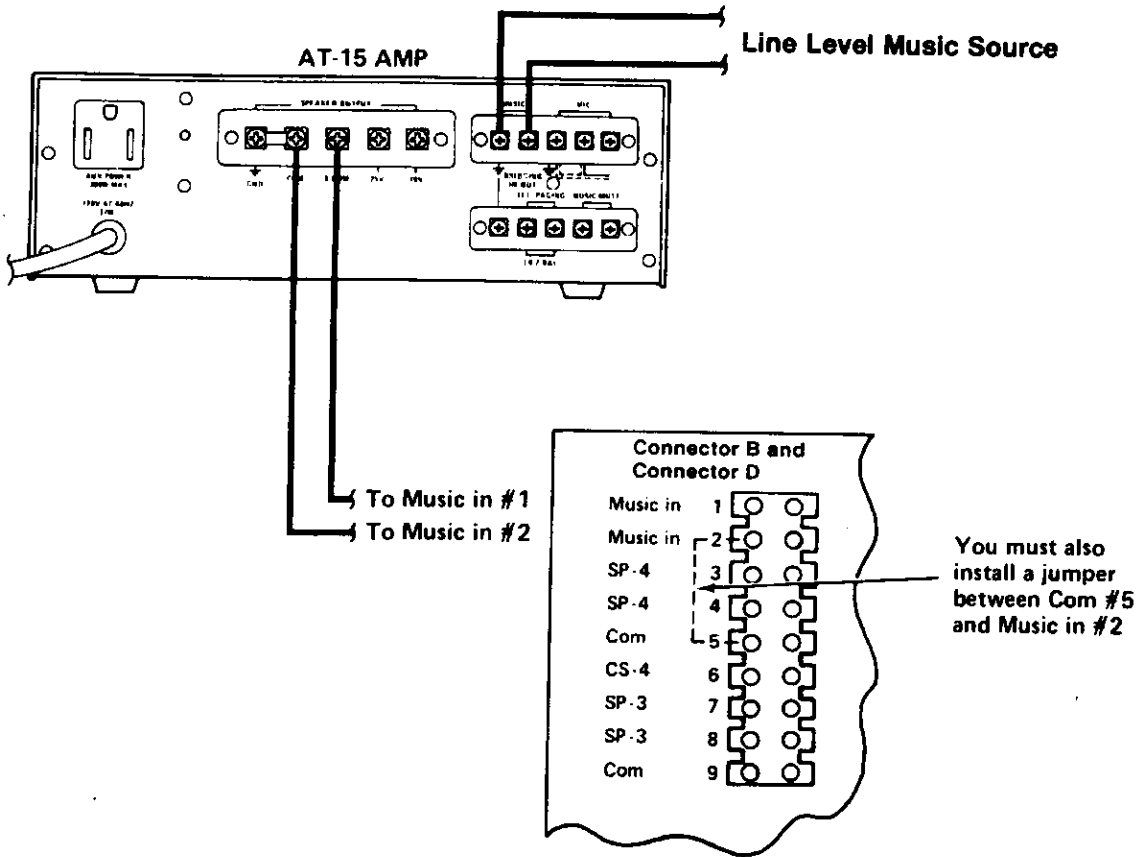

Figure 16 - Music Player Connections

RECOMMENDED SPEAKER/MICS, CALL SWITCHES AND ACCESSORIES

To ensure the best D-120 sound quality, use one of the following 3M speakers, switches, etc.

<u>3M Part Number</u>	<u>Description</u>	<u>Normal Application/Location</u>
78-8028-9195-8 [*]	Speaker/mic and call switch assembly with stainless steel faceplate	Mount on canopy post to talk to inside. Includes weather-resistant call switch.
78-8028-9196-6 [*]	Speaker/mic assembly with stainless steel faceplate	Mount on canopy post to talk to inside. Requires separate call switch.
78-8028-9174-3 ^{**}	Call switch assembly with stainless steel faceplate	Mount on canopy post to signal inside. Use with speaker/mic assembly.
78-8016-9810-7	Outside, horn-type speaker/mic with mounting base	Mount on a pump island post for paging and monitoring.
78-8028-9047-1 78-6911-2297-8	Security speaker/mic with backbox Security speaker/mic and call switch	Best security with slight loss of voice quality.
78-6911-2379-4	Heavy-duty security handset (telephone-type) with back box for surface mounting.	Outside call-in. For private communication in high-noise area. Mounted on post.
78-6911-1442-1	Premium footswitch	Eliminates holding the channel keypad depressed while talking.

* Requires stainless steel back box (78-8028-9192-5) for surface mounting.

** Requires back box (26-1004-3627-3) for surface mounting. Use a standard single-gang electrical box for recessed mounting or conduit rough-in.

SERVICE ASSISTANCE

Many new installation problems result from wiring errors or overlooked instructions, so recheck all instructions and wiring connections if a problem occurs. Be sure that you have correctly set the internal jumper switches for the options used. Also be sure that the internal volume controls were adjusted as described on page 11 of these instructions.

If you need technical assistance during or after this installation, call 3M Sound Products Technical Service at (612) 733-4912/4913.

Installation Instructions

Model 491AAV D-120V 12-Channel VOX Intracom System 78-9236-5496-2

A. Introduction

These instructions supplement the enclosed standard D-120 installation instructions to explain the added requirements of this special VOX (Voice Operated Switching) version of the D-120 Intracom. VOX units require a special gooseneck microphone attached to the rear of the upper cabinet. Read these instructions completely before proceeding to install and use the D-120V.

B. Installation

Follow the standard D-120 instructions to mount and connect the D-120V. The externally mounted microphone replaces the internal one (present on other models) and proper VOX operation requires that you use only this microphone.

C. VOX Sensitivity Adjustment

A VOX sensitivity control located (and marked) on the bottom of the D-120V requires adjustment using the special (plastic) screwdriver tool included with the D-120V. This control adjusts for the voice level required to activate the talk switching. If set too high, background sounds will trigger switching. If set too low, the switching may fail to activate or may drop out prematurely. It is best to set this adjustment while the person who will operate the D-120V talks in a normal voice at a specified distance from the microphone, preferably about two inches. Make this adjustment after setting the LISTEN (operator), TALK and ALERT volumes in accordance with the D-120 instructions.

D. Service Information

Most new installation problems result from overlooked instructions or from wiring errors, so recheck everything if a problem occurs. Dealer personnel should refer to the 3M service manual for schematics and parts information on this product.

Customers should contact their local authorized 3M Sound Products dealer for service of this product. To replace the special VOX microphone, order 3M part number 78-8050-8495-7 from your local dealer. For the name of your local dealer, or to obtain installation or repair assistance, contact 3M for technical assistance at 800/328-0033.

3M Sound Products

3M Center Bldg. 551-1E-02
St. Paul, MN 55144-1000

